

Solar Pumping Inverter

User's Manual



Preface

Thank you very much for using the GW series solar water pump inverter.

In order to give full play to the product performance and guarantee the safety of user and equipment, before installation and use, please carefully read the manual.

In order to facilitate daily inspection and maintenance of inverter and understand abnormal reason and solutions, please keep the instruction properly.

If you have any questions or special requirements during use, please contact with our company's product dealer or directly contact with our company's technical service center.







If the manual contents change, we may not offer notice.

Contents

Precautions	II
Chapter I Product Introduction	1
1.1 Introduction to Solar Pumping System	1
1.2 Product Characteristics	2
1.3 Inverter Specification	3
Chapter II Installation and Wiring	7
2.1 Procurement Inspection	7
2.2 Dimension and Weight	7
2.3 Installation Diagram	10
2.4 Wiring Diagram	12
2.5 Assemble DC Connector	16
2.6 Assemble AC Connector	17
2.7 Introduction to the Wiring of Water Level Sensor	20
Chapter III Operation Control	22
3.1 Panel Layout and Introduction	22
3.2 Panel Operation Method	23
3.3 Work Mode	24
Chapter IV: Failure Diagnosis	25
4.1 Explanation and Solution for Fault Code	25
Chapter V Maintenance	27
5.1 Daily Inspection and Maintenance	27
5.2 Inspection and Replacement of Quick-wear Parts	28
5.3 Storage and Maintenance	28
Quality Assurance	29
Warranty Card	32

Precautions

The safe operation of the product is subject to correct transportation, installation, operation, and maintenance. Before conducting these tasks, please pay attention to relevant safety instructions. The warnings related to safety in the manual are listed as follows:

	<p>Grounding Wire of Equipment</p>
	<p>AC Value</p>
	<p>DC Value</p>
	<p>Phase</p>
	<p>Before operating inverter, please read the instruction.</p>
	<p>In order to avoid electric shock, break off machine with PV terminal and AC terminal for at least 5 minutes, then contact the wire of machine output terminal and input terminal</p>

◆ Procurement Inspection

 <p>Warning</p>
<p>1. If the inverter is found to suffer damage or lack in component and part, do not install it, or else it may cause accident!</p>

◆ Installation

 <p>Warning</p>
<p>1. In order to guarantee good effect of convection cooling, the inverter shall be installed vertically. Keep at least 10cm space between upward side and downward side.</p> <p>2. Try to install it in the indoor place with ventilation opening or air interchanger. It is forbidden to install it directly under sunshine.</p>

3. During installation, do not discard residue of drill hole into inverter cooling fin or fan, which may affect heat dissipation.

◆ Wiring



Danger

1. The wiring shall be conducted by qualified electric technician, or it may cause electric shock or fire disaster.
2. Before wiring, please confirm that the input power has been cut off, or else it may cause electric shock or fire disaster.
3. The grounding terminal must be grounded reliably, or else the inverter shell may have electricity.
4. The solar array, motor load, and inverter model selection shall be reasonable, or else it may damage equipment.



Warning

1. Please use specified moment of force to tighten terminal, or else it may cause fire disaster.
2. Do not connect capacitance or phase advance LC/RC noise filter in the output end of inverter. When the distance between inverter and motor load is over 100m, it is advised to use output reactor.

◆ Operation



Danger

1. Power on after confirming that the wiring is correct, or it may damage inverter or fire disaster.
2. During electricity, do not change wiring, or else it may cause electric shock.

**Warning**

1. Before the first operation, please adjust some control parameters according to operation instruction. Do not alter the control parameters of inverter at random, or else it may damage the equipment.
2. During operation, the temperature of radiator is very high. Do not touch the radiator, or else it may scald you.
3. When height above sea level exceeds 1000m, the inverter shall be used under rated power. If the height increases by 1500m, the output current shall decrease by 10%.

◆ Miscellaneous**Danger**

1. Assign qualified electric technician for maintenance and inspection.
2. During power-up state, do not remove the inverter. After outage, wait for 5 minutes at least, then conduct maintenance and inspection, so as to avoid that the residual voltage on electrolytic capacitor of major loop may cause damage to people.
3. It is forbidden to transform the inverter without authorization, or else it may damage personnel or equipment.
4. When handling scrapped inverter, please dispose the inverter as industrial waste. The inner electrolytic capacitor may explode during burning. Some components and parts may generate hazardous and harmful gas during combustion.

Chapter I Product Introduction

1.1 Introduction to Solar Pumping System

Solar Pumping System is widely applied in domestic water, agricultural irrigation, forestry watering, desert control, grassland animal husbandry, island water supply, water treatment project, etc. During recent years with the enhancement of new energy utilization, solar pumping system is widely applied in the landscape and water spray system of municipal works, urban square, garden sightseeing, tourist resort, hotel, and residential community. The system consists of solar cell array, pumping inverter, and water pump (figure 1-1). Based on the design philosophy of saving water first, the system omits energy storing device such as accumulator.

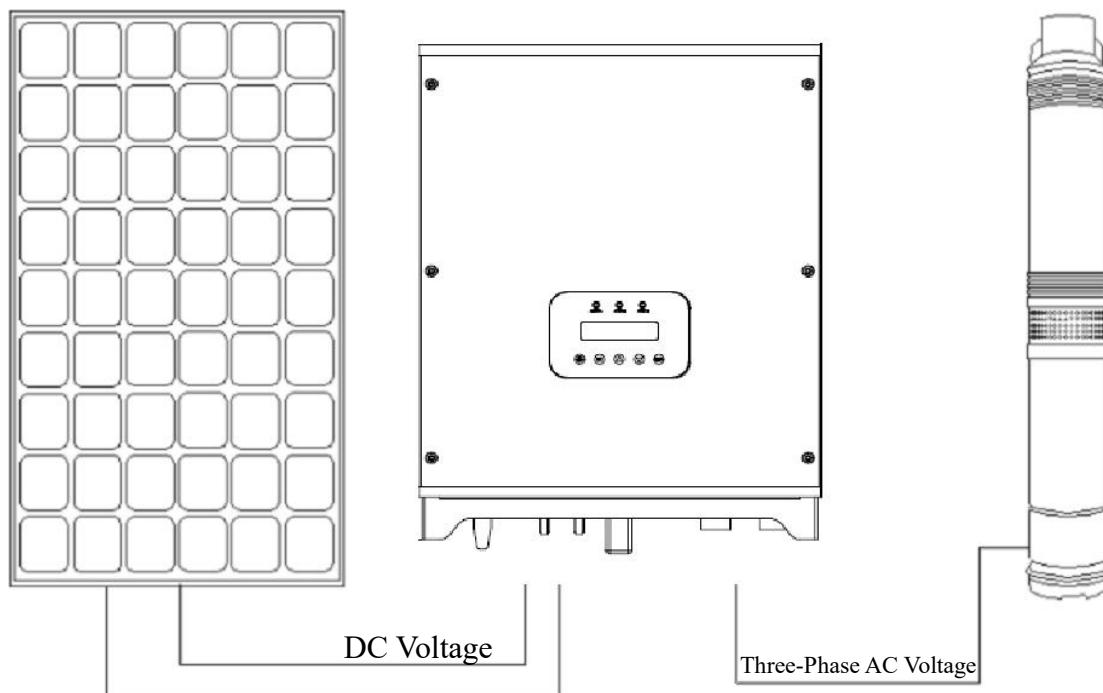

Figure 1-1 Structure of Solar Pumping System

The solar cell array is made from the series connection and parallel connection of several solar cell modules, which absorb solar radiation energy and transform it into electric energy, so as to supply electric power for the whole system. The pumping inverter controls and regulates the operation of the system, transforms the direct current of solar cell array into alternating current to drive water pump. In addition, according to the change of sunlight intensity, regulate output frequency timely, to realize MPPT (Maximum Power Point Tracking). The water pump is driven by three-phase AC motor. It pumps water from deep well, river, and lake, then inject water into water storage tank/pool, or directly connect with irrigation system or fountain system, etc. According to actual requirements of system and installation, different types of water pumps such as centrifugal pump, axial flow pump, mixed-flow pump, or deep-well pump can be used.

1.2 Product Characteristics

On the basis of many-year research, development, and experiment, the pumping inverter (Figure 1-2) independently developed and produced by our company has the following advantages:

- ◆ Use independently-developed dynamic VI MPPT (Maximum Power Point Tracking) control method. The response speed is fast. Operation is stable and reliable. It solves the following problems: tracking effect is poor when sunlight intensity rapidly; operation is not stable; water hammer damage.
- ◆ All digital control. It has complete automatic operation, data storage, and complete protection functions.
- ◆ GW Solar Pumping Inverter is specially designed for solar water pump. The inner structure is more reasonable and professional.
- ◆ All key parts used in GW solar pumping inverter are made by international famous brands. The quality is reliable, service life is long, and quality assurance period is long.

Component and Part	Manufacturer	Country
IGBT Module	Infineon/Semikron	Germany
Electrolytic Capacitor	NCC/SANYOUNG/Equally	Japan/Korea
EMI Filter	VAC/Equally	Germany
DSP Control Chip	TI	America
PV Fuse	BUSSMAN/Equally	America

- ◆ The shell of GW solar pumping inverter is thick. The design process is improved through abrasive tool test for many times. The appearance is elegant and exquisite, model is compact, and weight is proper.
- ◆ GW solar pumping inverter integrates combiner box. It includes DC switch, lightning arrester, fuse, and optional components. It greatly simplifies and facilitates equipment installation and maintenance, but also effectively protects the equipment.
- ◆ Multiple communication interfaces such as RS485/GPRS(optional), etc. User can check or control the running status and running mode of the system in a remote place.
- ◆ The design of GW solar pumping inverter selects electric supply or diesel generator as standby inverter power supply, so as to meet the comprehensive requirements of water supply.
- ◆ GW solar pumping inverter has complete operation protection mechanisms, including output short circuit protection, IGBT module over current protection, acceleration/deceleration/ constant speed over current protection, acceleration/deceleration/constant speed overvoltage protection, input overvoltage/under voltage protection, motor overload protection, inverter overload protection, output side phase loss protection, inverter module overheat protection, grounding short circuit protection, and under load (anti-dry pumping) protection.

- ◆ The main circuit uses power module (PIM), and the reliability is higher.
- ◆ The small-power model uses completely-new aluminum shell, LCD display operation panel, and directly-insert connection terminal. The appearance is beautiful. The heat dissipation effect and protective properties are good.
- ◆ Upper and lower water level detection and control circuit are optional.
- ◆ Protection grade IP65; temperature of service environment: $-20 \sim +60^{\circ}\text{C}$.

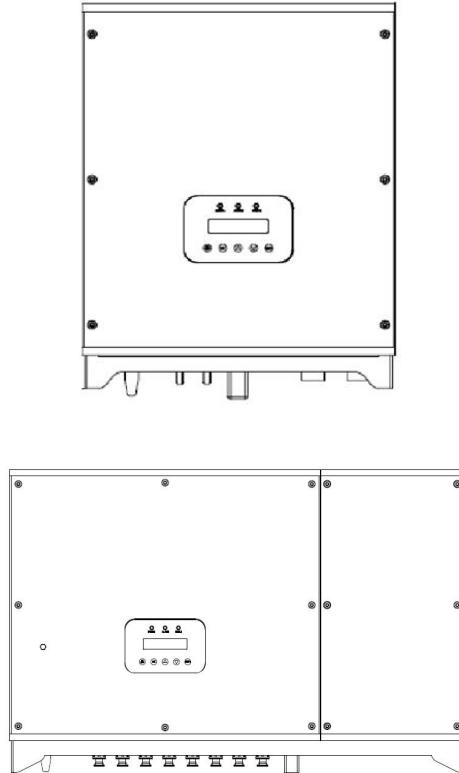
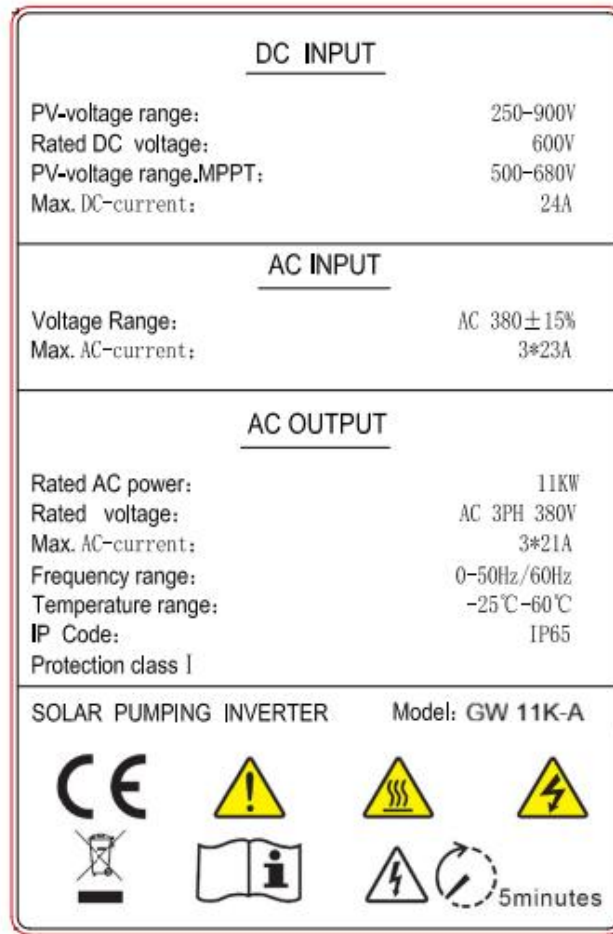

Figure 1-2 GW Series Pumping Inverter

1.3 Inverter Specification

1.3.1 Introduction to Nameplate and Model

The product nameplate is located at the right lower part of inverter. The nameplate includes important information such as product series, voltage, power grade, software version, and hardware version. Such information provides important basis for product application, maintenance, and after-sales service.



GW
11000
A
①
②
③

Figure 1-3 Introduction to Product Nameplate and Model

Identification	Introduction
1	Product Series
2	Rated Power (W) of Motor
3	A: with electric supply function None: without electric supply function
4	S: with single-phase None: three-phase
5	L:with 220V None:380V

1.3.2 Product Specification and Technical Index

Model	Max. DC input voltage (Vdc)	Recommen ded MPP voltage (Vdc)	Start voltage (Vdc)	Rated output power (W)	Max.AC output current(A)	Output frequency (Hz)	Rated output voltage (Vac)
GW 1.5K-SL	500	200-400	80	1500	10	0-50/60	1PH 220V
GW 1.5K-SLA	500	200-400	80	1500	10	0-50/60	1PH 220V
GW 2.2K-SL	500	270-400	80	2200	14	0-50/60	1PH 220V
GW 2.2K-SLA	500	270-400	80	2200	14	0-50/60	1PH 220V
GW 2.2K-L	450	270-400	80	2200	11	0-50/60	3PH 220V
GW 2.2K-LA	450	270-400	80	2200	11	0-50/60	3PH 220V
GW 3K	900	450-750	250	3000	8	0-50/60	3PH 380V
GW 4K	900	450-750	250	4000	10	0-50/60	3PH 380V
GW 5.5K	900	450-750	250	5500	11	0-50/60	3PH 380V
GW 7.5K	900	450-750	250	7500	18	0-50/60	3PH 380V
GW 9.2K	900	450-750	250	9200	21	0-50/60	3PH 380V
GW 11K	900	450-750	250	11000	24	0-50/60	3PH 380V
GW 13K	900	450-750	250	13000	28	0-50/60	3PH 380V
GW 15K	900	450-750	250	15000	30	0-50/60	3PH 380V
GW 18K5	900	450-750	250	18500	39	0-50/60	3PH 380V
GW 22K	900	450-750	250	22000	45	0-50/60	3PH 380V
GW 26K	900	450-750	250	26000	50	0-50/60	3PH 380V
GW 30K	900	450-750	250	30000	60	0-50/60	3PH 380V

GW 37K	900	450-750	250	37000	75	0-50/60	3PH 380V
GW 45K	900	450-750	250	45000	91	0-50/60	3PH 380V
GW 55K	900	450-750	250	55000	112	0-50/60	3PH 380V
GW 3K-A	900	450-750	250	3000	8	0-50/60	3PH 380V
GW 4K-A	900	450-750	250	4000	10	0-50/60	3PH 380V
GW 5.5K-A	900	450-750	250	5500	11	0-50/60	3PH 380V
GW 7.5K-A	900	450-750	250	7500	18	0-50/60	3PH 380V
GW 9.2K-A	900	450-750	250	9200	21	0-50/60	3PH 380V
GW 11K-A	900	450-750	250	11000	24	0-50/60	3PH 380V
GW 13K-A	900	450-750	250	13000	28	0-50/60	3PH 380V
GW 15K-A	900	450-750	250	15000	30	0-50/60	3PH 380V
GW 18K5-A	900	450-750	250	18500	39	0-50/60	3PH 380V
GW 22K-A	900	450-750	250	22000	45	0-50/60	3PH 380V
GW 26K-A	900	450-750	250	26000	50	0-50/60	3PH 380V
GW 30K-A	900	450-750	250	30000	60	0-50/60	3PH 380V
GW 37K-A	900	450-750	250	37000	75	0-50/60	3PH 380V
GW 45K-A	900	450-750	250	45000	91	0-50/60	3PH 380V
GW 55K-A	900	450-750	250	55000	112	0-50/60	3PH 380V



Warning: please select appropriate model according to solar cell array and motor load.



Warning: The input power in the above table refers to multi-channel total input power. The maximum input DC current of each group shall not exceed 15A.

Chapter II Installation and Wiring

2.1 Procurement Inspection

Our company has strict quality assurance system in aspects of product manufacturing, packaging, etc. In case of abnormal condition, please contact with our company’s product dealer, or contact with our company’s technical service center. We will provide you with solution as soon as possible. When you get the products, please confirm the following items:

Inspection Item	Inspection Method
Whether it accords with ordered products	Inspect nameplate of product
Whether it is damaged or falls off	Check the overall appearance
Whether host computer and parts are complete	Inspect according to product checklist
Whether tightening parts such as bolt are loosened	When necessary, use screwdriver for inspection

2.2 Dimension and Weight

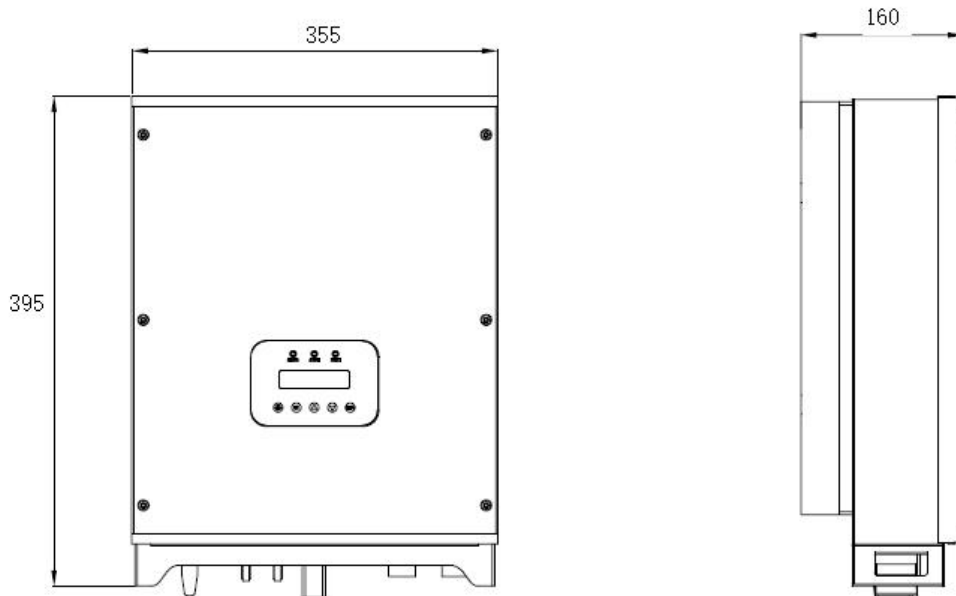

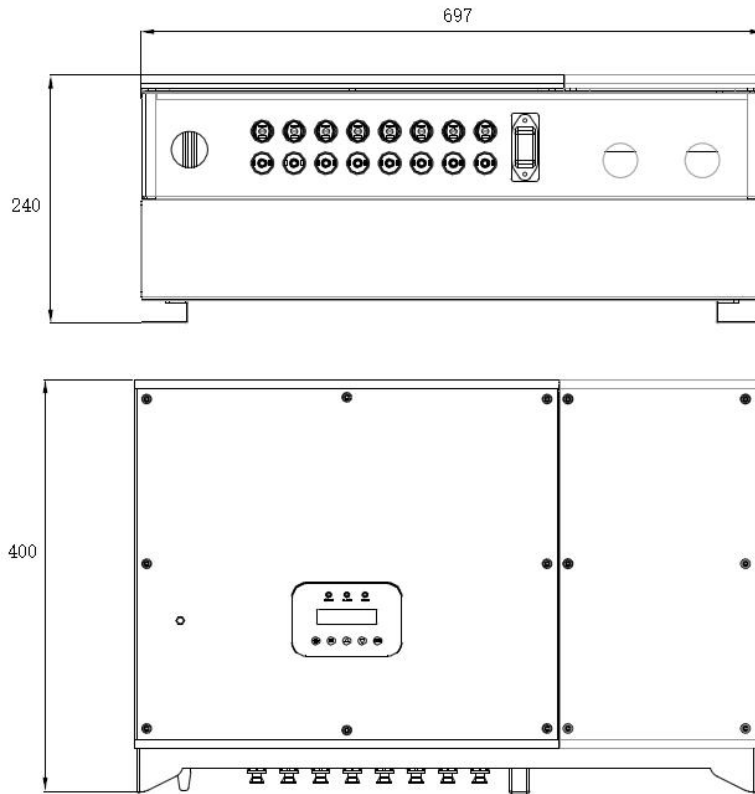

Figure 2-1 Product Appearance and Installation Dimension

Product Specification Parameter:

Model	Weight (Kg)	Appearance and installation dimension (mm)		
		L	W	H
GW 1500L	10	395	355	160
GW 2200L	10	395	355	160
GW 3000	11	395	355	160
GW 4000	11	395	355	160
GW 5500	11	395	355	160
GW 7500	13	465	365	168
GW 9200	13	465	365	168
GW 11000	13	465	365	168
GW 13000	19	505	415	190
GW 15000	19.5	505	415	190
GW 18500	21	505	415	190
GW 22000	21	505	415	190
GW 26000	21	505	415	190
GW 30000	21	505	415	190

GW 37000	30	697	400	240
GW 45000	30	697	400	240
GW 55000	30	697	400	240
GW 1500SL(A)	10	395	355	160
GW 2200SL(A)	10	395	355	160
GW 3000A	11.5	395	355	160
GW 4000A	11.5	395	355	160
GW 5500A	11.5	395	355	160
GW 7500A	14	465	365	168
GW 9200A	14	465	365	168
GW 11000A	14	465	365	168
GW 13000A	20	505	415	190
GW 15000A	20.5	505	415	190
GW 18500A	22	505	415	190
GW 22000A	22	505	415	190
GW 26000A	22	505	415	190
GW 30000A	22	505	415	190
GW 37000A	32	697	400	240
GW 45000A	32	697	400	240
GW 55000A	32	697	400	240



Warning: most models of GW series are hanging installation. Guarantee that the installation backboard can bear the weight of inverter.

2.3 Installation Diagram

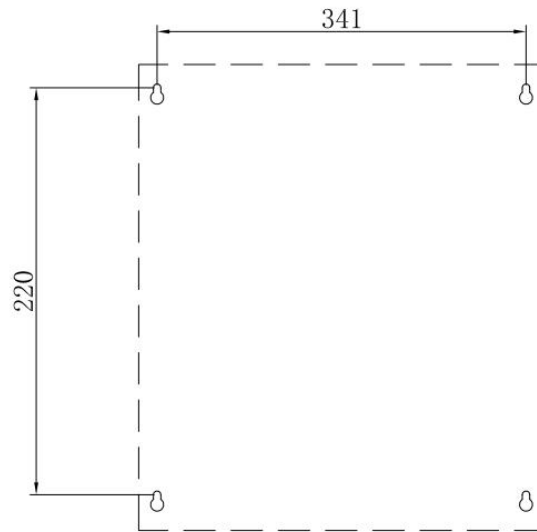

Figure 2-2 Installation Dimension Diagram of GW 1500 to 5500

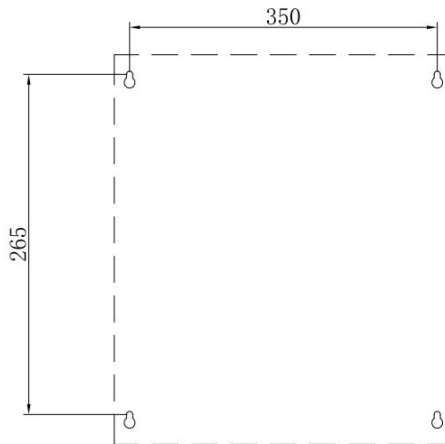

Figure 2-3 Installation Dimension Diagram of GW 7500 to 11000

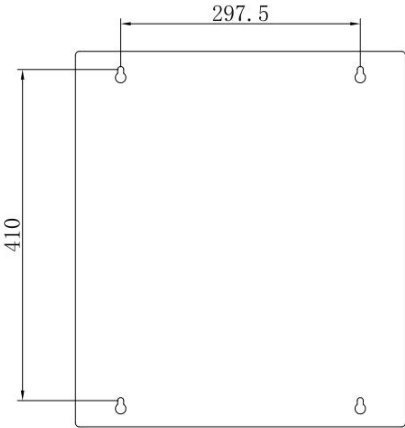

Figure 2-4 Installation Dimension Diagram of GW 15000 to 30000

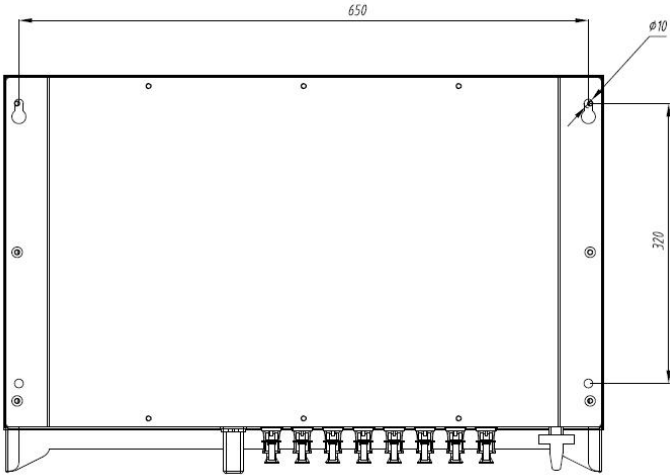

Figure 2-5 Installation Dimension Diagram of GW 37000 to 55000

2.4 Wiring Diagram

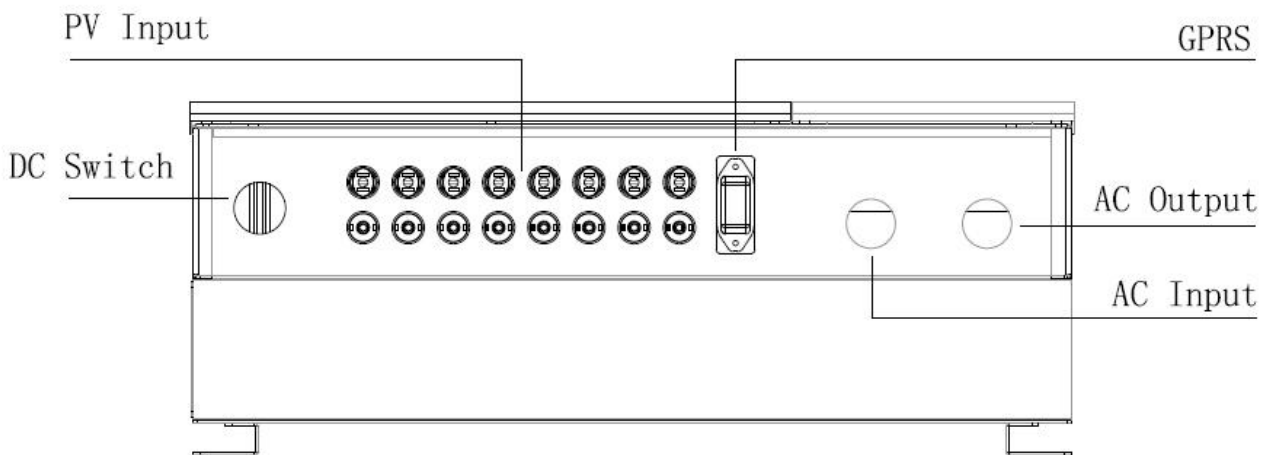
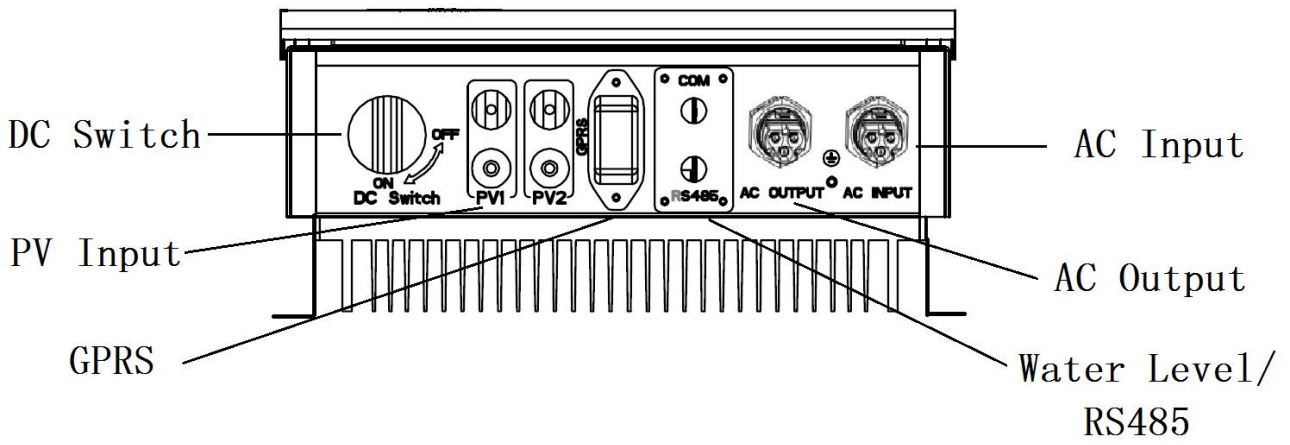

Figure 2-6 Terminal Diagram

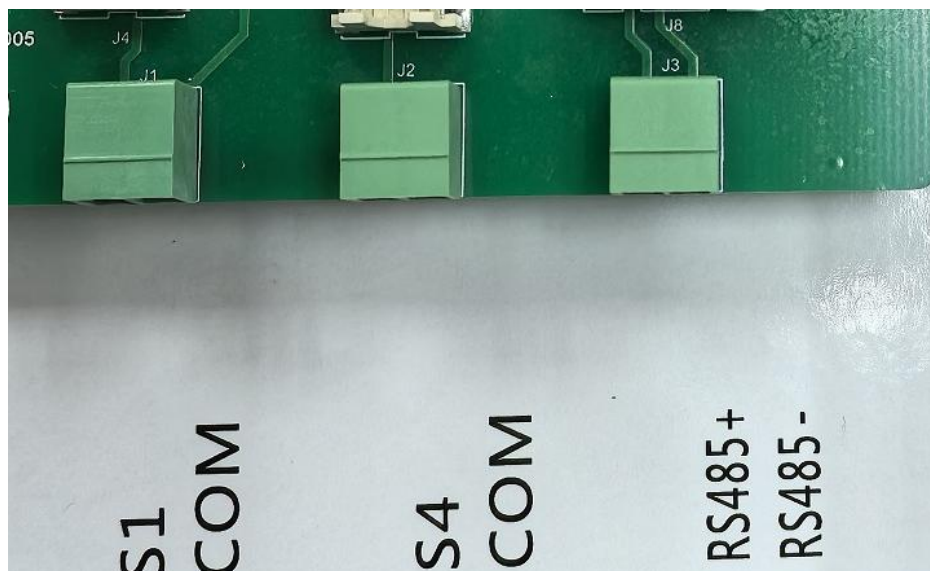
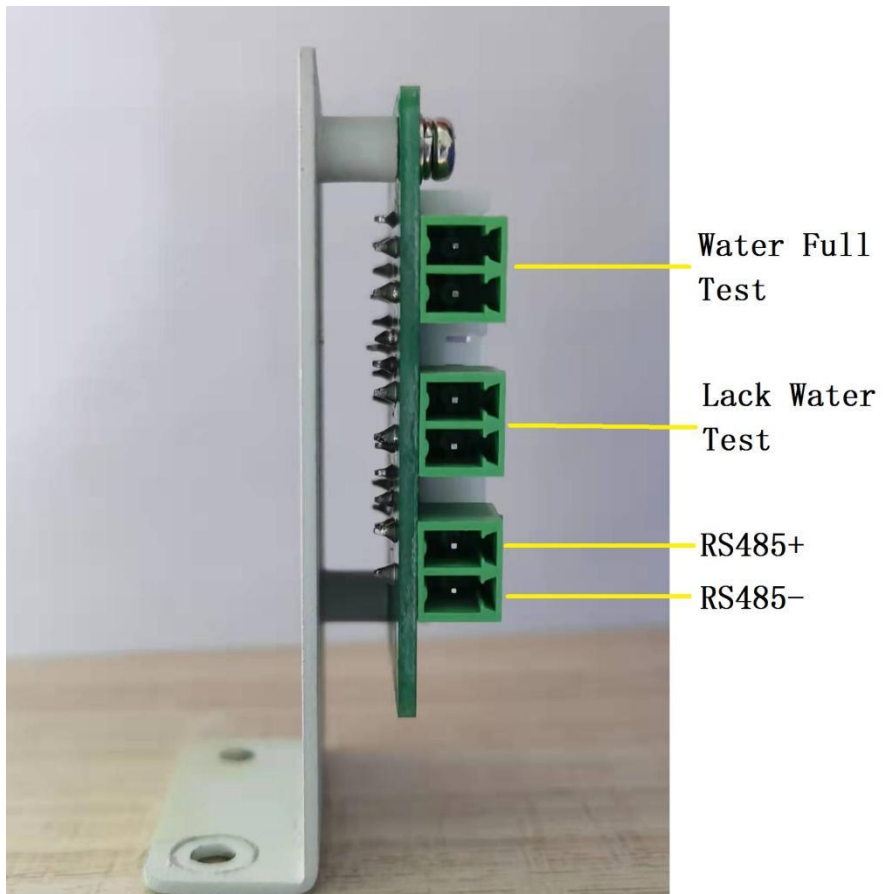

Figure 2-7 COM Terminal Diagram

Terminal Introduction

Socket	Terminal Introduction	Wiring Introduction
DC Input	PV+	Connect with the positive pole of solar array
	PV-	Connect with the negative pole of solar array
AC Output	PE	Connect with protective ground wire
	U	Connect with motor U phase
	V	Connect with motor V phase
	W	Connect with motor W phase
Water Level Sensor Input (Switch Value)	+12V	Power supply of water level sensor
	COM	Common signal grounding
	S2	Water-full signal of water tower (switching value)
	S4	Water shortage signal of water tower (switching value)
Communication	RS485+	485 communication
	RS485-	485 communication



Warning: the places of input sockets of DC positive pole and negative pole of different models are different. Please confirm according to plug.



Warning: the signal marshalling sequence of AC output sockets of different models are different. Please confirm according to the number on socket.



Warning: in order to guarantee that the system works normally, please select wire dimension according to the following principle.

2.4.4 Recommended Diameter of Wire (mm²)

model	Recommend ed output current(A)	Output voltage(V)	length≤	length≤	length≤	length≤	length≤	length≤	length≤
			30m	60m	90m	120m	150m	180m	210m
GW 1500	10	1/3HP 220V	1.5	2.5	2.5	6	6	6	6
GW 2200	14	1/3HP 220V	1.5	2.5	2.5	6	6	6	6
GW 3000	8	3HP 380V	1.5	2.5	2.5	6	6	6	6
GW 4000	10	3HP 380V	1.5	2.5	2.5	6	6	6	6
GW 5500	11	3HP 380V	2.5	2.5	4	6	6	6	6
GW 7500	18	3HP 380V		2.5	4	6	6	10	10
GW 9200	21	3HP 380V		4	4	6	10	10	10
GW 11000	24	3HP 380V		4	6	10	10	10	16
GW 13000	28	3HP 380V		6	6	10	10	10	10
GW 15000	30	3HP 380V		6	6	10	10	16	16
GW 18500	39	3HP 380V		6	10	10	16	16	25
GW 22000	45	3HP 380V			10	16	16	25	25
GW 26000	50	3HP 380V			16	16	25	25	25
GW 30000	60	3HP 380V			16	16	25	25	25
GW 37000	75	3HP 380V			25	25	25	35	35
GW 45000	91	3HP 380V			35	35	35	50	50
GW 55000	112	3HP 380V			35	35	50	50	50

Units: mm²



Notice: the environment temperature of the above recommended wire dimension is ≤50°C.

 Notice: large-power wall-mounted model uses multiple-channel DC input. The dimension of DC wire of each channel shall be selected according to the above table.

2.5 Assemble DC Connector

2.5.1 Strip the cable 6-8mm, then connect the bare wire core into core tube of connector .

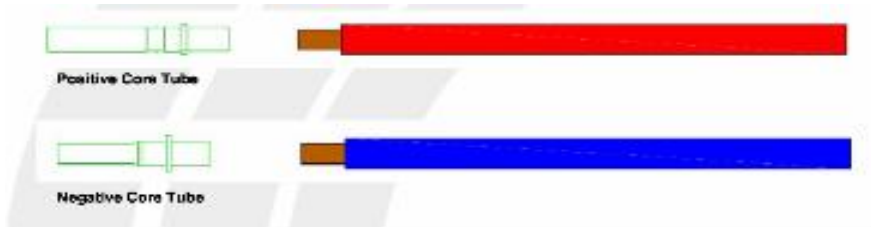

Figure 2-8 DC Line connects with wiring board

2.5.2 Crimp contact barrel by using a hex crimping die. Put the contact barrel with striped cable in the corresponding crimping notch and crimp the contact. Insert the core tube into GWot of connection until hear the voice indicating in place.

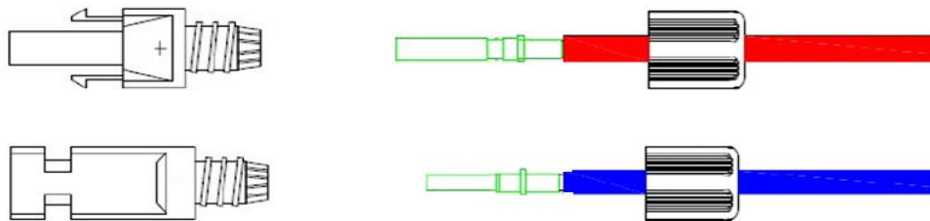

Figure 2-9

2.5.3 Insert contact cable assembly into back of the male and female connector. Tighten nuts according to the opposite direction. Now wiring is finished.

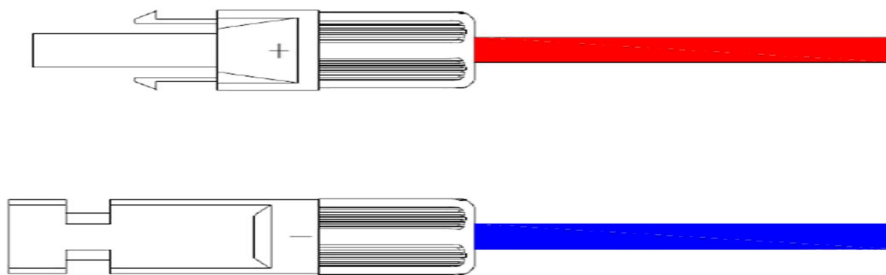

Figure 2-10

2.5.4 The PV importation that will assemble a good DC conjunction machine to make an effort to insert Inverters carries and link OK after hearing the sound of "click".

2.6 Assemble AC Connector

2.6.1 GW 1500~GW 2200 Single-phase Output connector Wiring Diagram

1)Wiring Diagram of Two-Wire Water Pump

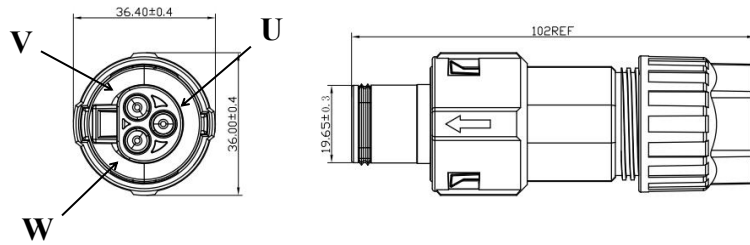

Figure 2-11 Terminal internal diagram

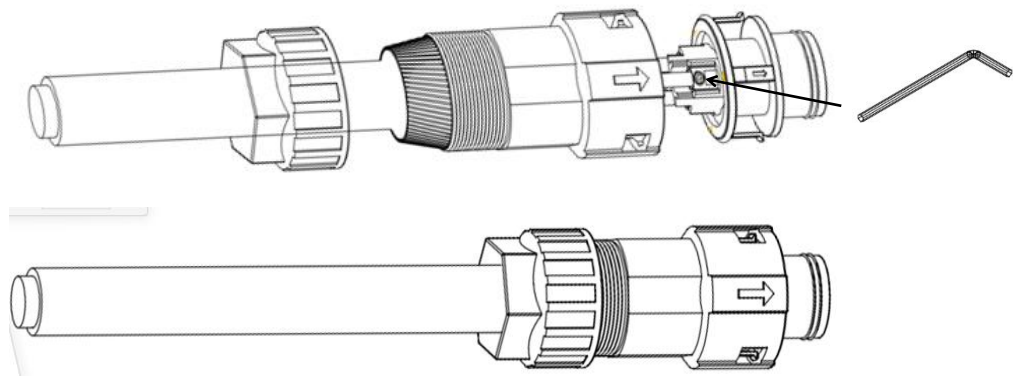
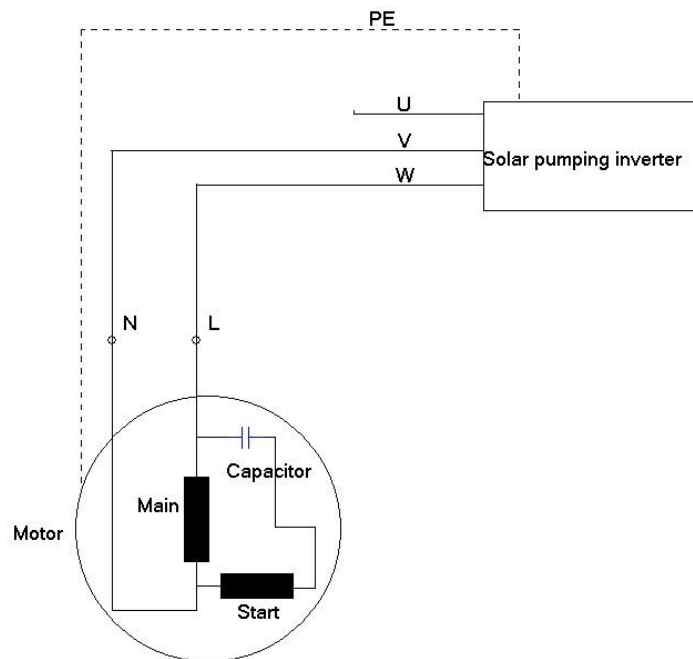
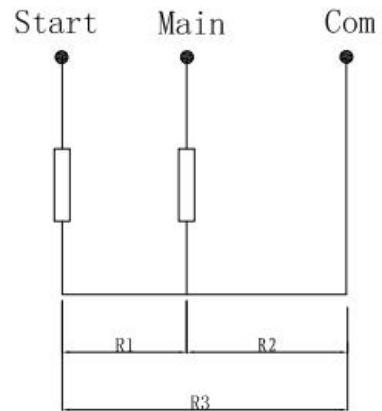
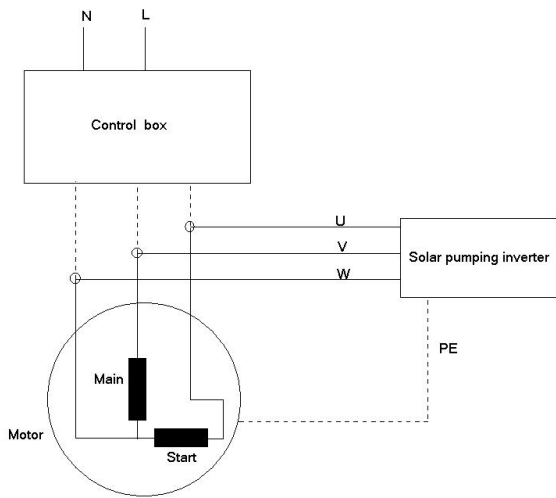

Figure 2-12 Terminal connection diagram



2) Wiring Diagram of Three-Wire Water Pump



Can Use a multimeter to determine terminals

$$R1 > R2 > R3$$

Figure 2-13 Wiring Diagrams of GW 1500 to GW 2200

Figure 2-14 How to identify the primary and secondary winding

2.6.2 GW 1500~GW 30K Three-phase Output connector Wiring Diagram

Type 1 connector

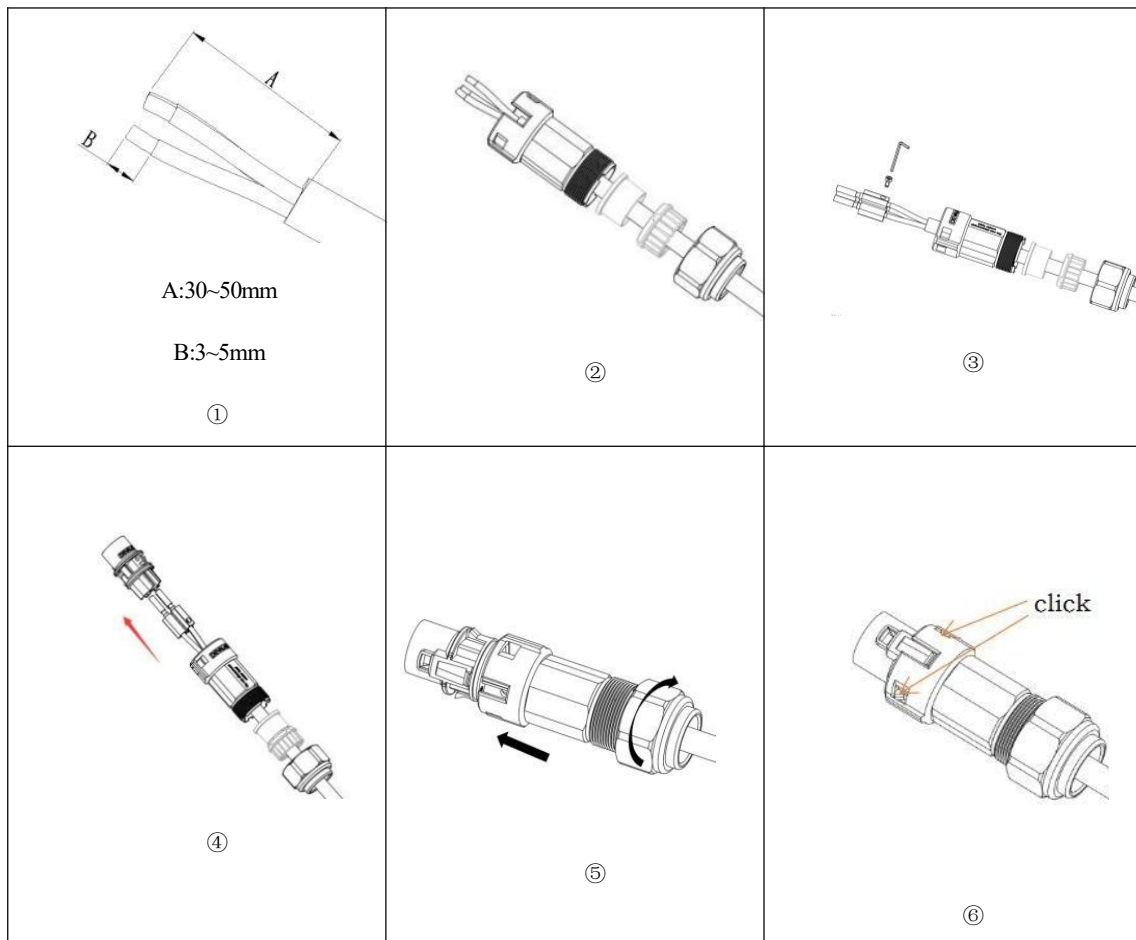

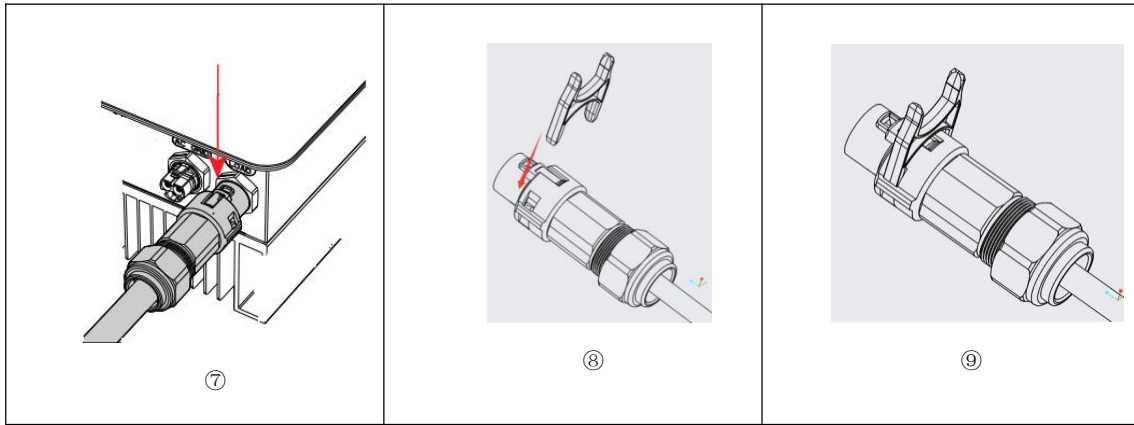

Figure 2-15

Type 2 connector

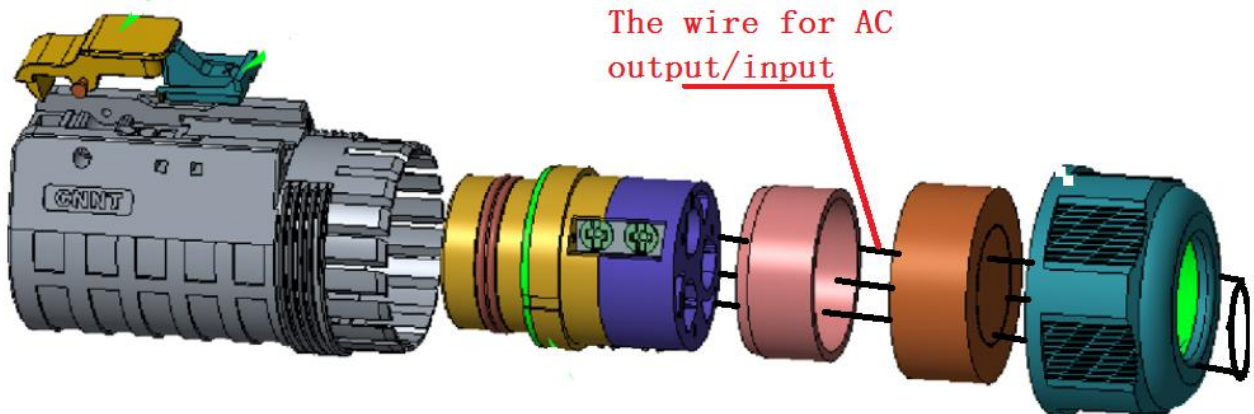



Figure 2-16

 Warning: The PE connect to chassis front panel

 Warning: risk of electric shock! Before shifting solar panel, disconnect pumping inverter AC and DC. Besides, allow 5-minute internal capacitance discharging.

2.6.3 GW 37KW~GW 55KW Three-phase Output connector Wiring Diagram



Figure 2-17

 Warning: The PE connect to chassis front panel.

2.7 Introduction to the Wiring of Water Level Sensor

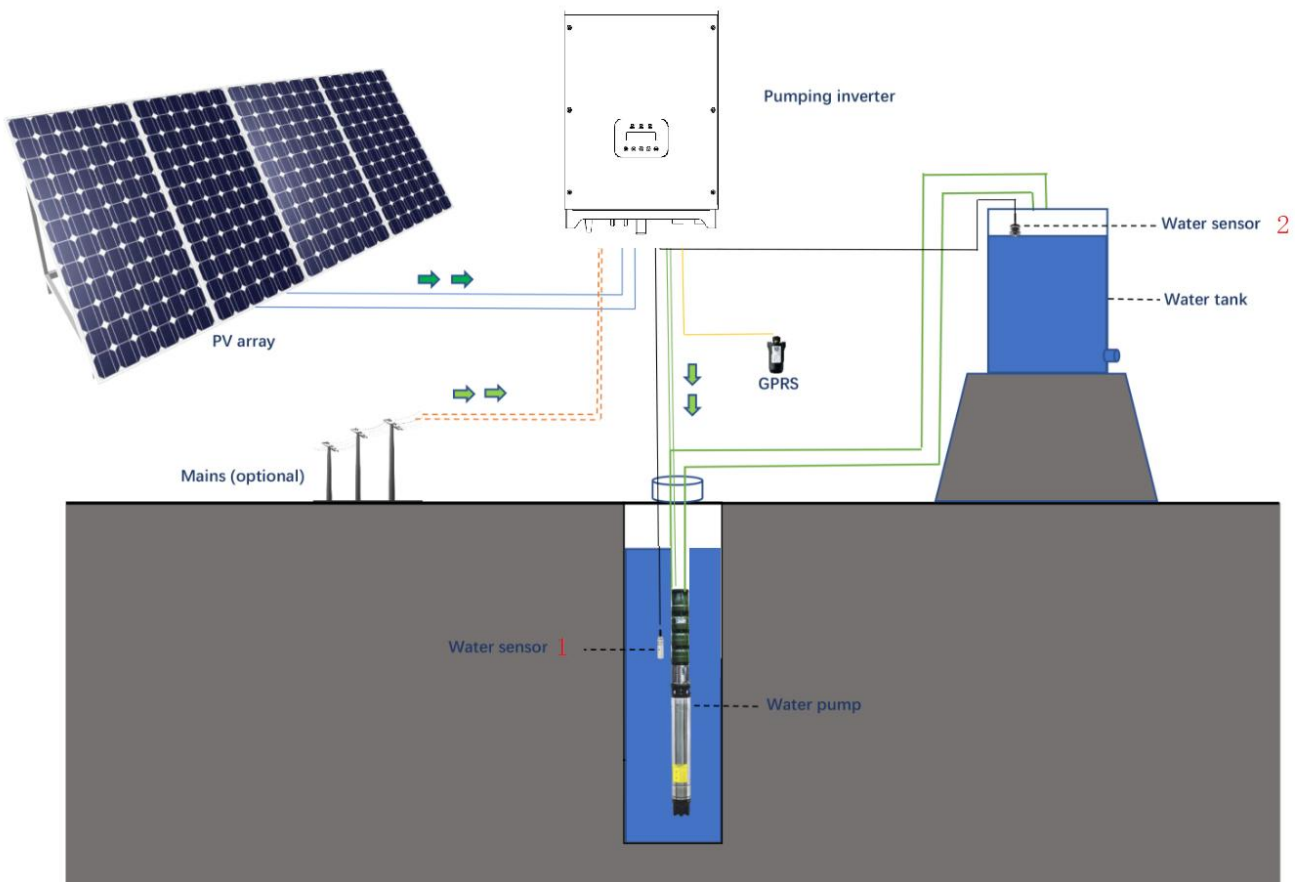

Figure 2-18 Wiring Diagram of Water Level Detector



Notice: connect water level sensor 1 and detect water shortage. Respectively connect two signal lines of sensor with S4 and COM of I/O circuit board. When water level sensor 1 detects that the water level of well is lower than the level set by sensor, the pumping inverter will delay for 60s, then turn off output protection pump. The water level recovers. Wait for 600s, then the pumping inverter re-works normally.



Notice: connect water level sensor 2 to defect whether water is full. Connect two signal lines of sensor with S2 and COM. When water level sensor 2 detects that the water level of water tank exceeds the level set by sensor, the pumping inverter delays for 60s and turns off output; when water level is lower than set level, wait for 120s, then pumping inverter re-starts to work normally.

Chapter III Operation Control

3.1 Panel Layout and Introduction

Solar Pumping Inverter uses LCD operation panel. The operation panel is shown in the figure, including 3 LED lights, LCD display and 5 keys.

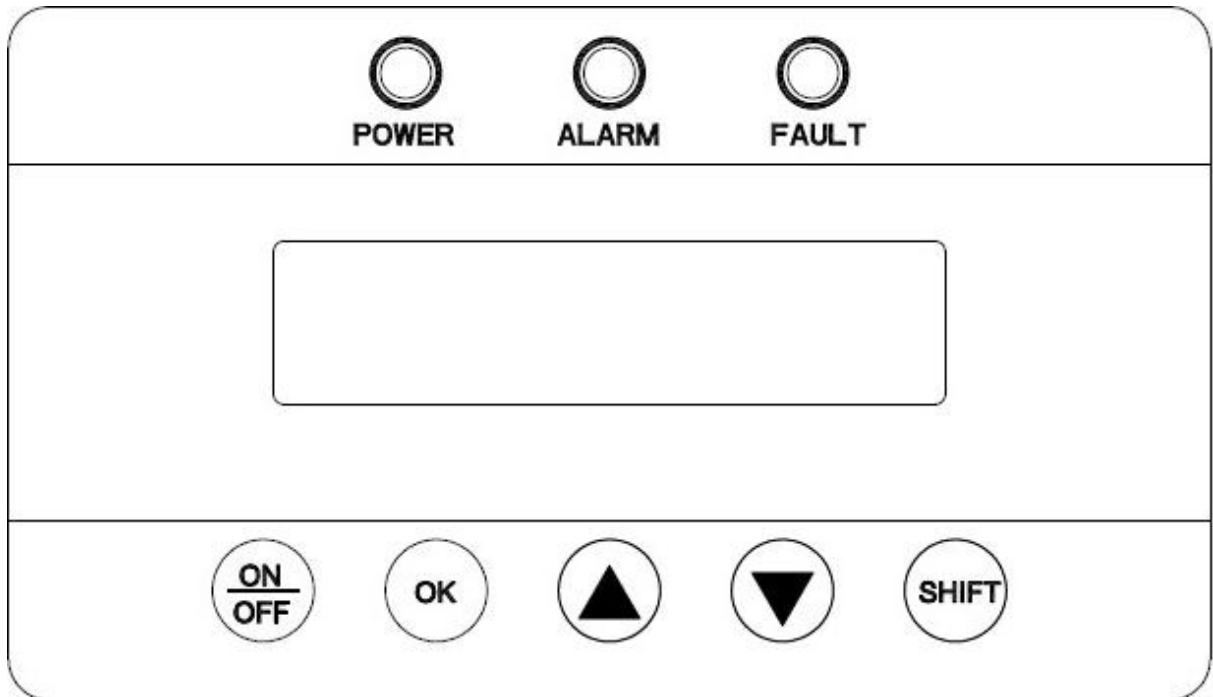









Figure 3-1 Keyboard Layout and Each Part Name

Indicator and Key	Name	Function Introduction	
POWER	Operation Indicator	Green	Bright: Inverter Operates
ALARM	Warning Indicator	Yellow	Bright: warning and terminal mode
FAULT	Failure Indicator	Red	Bright: system failure
	Operation/Stop Key	1. Press for a short time, then the inverter starts control; 2. Press for 2s, then inverter stops control.	

Indicator and Key	Name	Function Introduction
	Confirm/Programming Key	1. Press for a short time to enter programming mode. After altering parameter, “press for a short time” to confirm the alteration 2. Press for 2s to return to the previous menu.
	Increment Key	1. When control parameter displays state, increase parameter number or parameter value; 2. When operation displays data state, according to operation mode, increase output frequency or display current operation data.
	Decrement Key	1. When control parameter displays state, press for a short time to decrease parameter number or parameter value. 2. When operation shows data state, according to operation mode, decrease output frequency or display current operation data.
	Shift Key	1. After entering mode of parameter editing, press the key for a short time to conduct shifting; 2. When machine operates normally, press the key to see the parameter of main interface.

3.2 Work Mode

The inverter includes three work modes: keyboard manual mode, fully-automatic work mode, GPRS work mode (optional). The default mode is fully-automatic work mode.

1: Keyboard manual work mode: menu P00. Setting P00.01=0. Press  key to operate. Press  key for 2s, then the inverter stop working.

2: Fully-automatic work mode: menu P00. Setting P00.01=1. When sunlight is strong enough, the inverter will automatically trace maximum power point. Under such mode, refer to inverter’s operation parameter and DC switch to turn on/off the machine.

3: GPRS work mode (optional): menu P00. Setting P00.01=2. Under such mode, bind cell phone number. Send messages to set startup, shutdown, parameter inquiry, etc.



Warning: do not change menu P00 parameters. The default mode is fully-automatic work mode.

3.3 Introduction to function parameters

SN	Name	Scope	Introduction	Factory Value
P00.01	Operation code channel	0~2	0: keyboard operation code channel (LED is off) 1: terminal operation code channel (LED flickers) 2: communication operation code channel (LED is bright)	1
P02.01	Rated power of asynchronous motor	0.1 ~ 3000.0	0.1 ~ 3000.0kW	Model confirmation
P02.02	Rated frequency of asynchronous motor	0.01 ~ P00.03	0.01 ~ P00.03	50.00Hz
P02.04	Rated voltage of asynchronous motor	0 ~ 1200	0 ~ 1200V	Model confirmation
P02.05	Rated current of asynchronous motor	0.8 ~ 6000	0.8 ~ 6000A	Model confirmation

Chapter IV: Failure Diagnosis

4.1 Explanation and Solution for Fault Code

GW series solar pumping inverter has complete protection. When system suffers failure, the inverter will take protective measures: the general protective measures are to stop the output of drive signal of motor and forbid to re-start within a certain period.

When failure or protection happens, the failure or protection needs to reset the inverter. Power off input power supply, then power on it. If the failure is not still settled, please contact with manufacturer to settle it.

The common failures are listed as follows:

Fault code	Possible reason	Countermeasure
Inc over Volt (Error 7)	1)PV input is too high 2)The pump type is difference	1)Check the solar array 2)Adjust acceleration speed time(P00.11)
Dec over Volt (Error 8)		
Con over Volt (Error 9)		
Vbus low (Error 10)	PV input is too low or the sunshine is very weak	Check the solar board
Inc over current (Error 4)	1) The pump rated power is very great. 2) PV voltage is low 3) The pump wiring is very long 4) The pump type is difference 5) The pump damage or pipeline blocking	1) Change a small pump 2) Check the solar board 3) Cut short the pump wiring or add a reactor 4) Adjust acceleration speed time (P00.11) 5) Check the pump or pipeline
Dec over current (Error 5)		
Con over current (Error 6)		
Overload Tel(Error 11)	Load is too large	Let up the pump rated power or check the pump whether damage
Overload VVVF (Error 12)	Inverter load is too large	Let up the pump rated power or check the pump whether damage
IGBT short out (Error 20)	Output short out or circuit damage	Check the wiring or seek services from manufacturer

Inv Overtemp (Error 16)	Air flue is blocked Environment temperature is too high	1) Clean air flue or improve ventilation 2) Check the fans for inverter
Scarce Phase Out (Error 14)	Equipment or circuit damage	1) Check the wiring 2) Seek services from manufacturer
Curr test Fault (Error 19)		Seek services from manufacturer
Empty Rotate (Alarm 132)	Water pump's connection wires are all open circuit. Water pump does not match inverter.	Check water level. Check whether the water pump wiring condition and water pump power meet the requirements of inverter capacity
Lack Water (Alarm 133)	Water shortage warning. If water is provided, it can recover automatically	
Water Full (Alarm 130)	When water level decreases. It can recover automatically	
Com Fault (Error 18)	Device or circuit damage	Reset or seek services from manufacturer



Warning: before resetting, completely find out failure reasons and eliminate the reasons. If it fails to reset or suffers failure again, find out the reasons. The continuous resetting will damage inverter.

Chapter V Maintenance

5.1 Daily Inspection and Maintenance

Affected by environment temperature, humidity, vibration, and inverter internal component aging, the inverter may suffer some potential problems during operation. In order to stably operate the inverter for a long term, conduct periodical inspection once each year.

5.1.1 Requirements of Inspection and Maintenance

1. The inspection shall be conducted by professional technician. When necessary, cut off the power supply of inverter.
2. Avoid leaving metal components and parts in inverter, or else it may damage the equipment.
3. The inverter has conducted electrical insulation experiment before leaving factory, so the user needn't conduct high-voltage insulation test.
4. If you intend to conduct insulation test on inverter, all input and output terminals must be short circuit reliably. It is forbidden to conduct insulation test on single terminate. Please use 500V megameter during test.
5. It is forbidden to use megameter to measure control loop.
6. When conducting insulation test on motor, remove the connecting line between motor and inverter.

5.1.2 Key Points of Inspection and Maintenance

Please use the inverter under the environment recommended in the manual and conduct inspection and maintenance according to the following table.

Inspection Frequency		Inspection Item	Inspection Content	Judgment Standard
Daily	Periodically			
√		Operating Environment	1. Temperature and humidity 2. Dust and gas	1. Temperature <50°C 2. Humidity <90%, without moisture condensation 3. No peculiar smell. No combustible or explosive gas
	√	Cooling System	1. Installation environment 2. Radiator	1. The ventilation of installation environment is good 2. The air flue of radiator is not blocked
√		Inverter Body	1. Vibration, temperature rise 2. Noise 3. Wire, terminal	1. Vibration is stable and shell temperature rise is normal 2. No abnormal noise or peculiar smell 3. Tighten the screw
√		Motor	1. Vibration, temperature rise 2. Noise	1. Operate stably. Temperature is normal. 2. No abnormal noise
√		Input and Output Parameter	1. Input Voltage 2. Output Current	1. Input voltage is in specified scope 2. Output current is under rated value

5.2 Inspection and Replacement of Quick-wear Parts

5.2.1 Filter Capacitor

The pulsating current of main loop will affect the performance of filter capacitor of aluminium electrolysis. The affected degree and environment temperature are related to service environment. Under normal conditions, the inverter shall change electrolytic capacitor once every 10 years. When electrolyte of electrolytic capacitor leaks, safety valve emits, or capacitance expands, replace it immediately.

5.2.2 Fan cooling

In GW series pumping inverter, the inverter above GW 15K has cooling fan inside. The service life of cooling fan is about 15000 hours. If fan has abnormal noise or generates vibration, replace it immediately.

5.3 Storage and Maintenance

5.3.1 Storage

After purchasing inverter, if you do not use it temporarily or decide to store it for a long time, pay attention to the following items:

1. Avoid putting inverter on the places in which temperature is high, air is humid, or places where there is vibration or metal dust. Guarantee good ventilation.
2. If the inverter is not used for a long term, the internal filter capacitor characteristic will decrease. Power on twice every two years to recover the characteristics of filter capacitor. At the same time, check the functions of inverter. During power-on, gradually increase the voltage through DC power supply. The power-on time shall not be less than 5 hours.

5.3.2 Maintenance

The warranty period of inverter is 2 years (since production date). During warranty period, if inverter suffers failure or damage under normal conditions, our company provides maintenance service free of charge. After warranty period, our company also provides paid maintenance services.

During warranty period, if the failure is caused due to the following reasons, some maintenance fees will be charged.

1. Failure caused by violation of operation manual or standards;
2. Without authorization, user repairs and transforms the inverter.
3. Failure caused by improper storage;
4. Use inverter for abnormal functions;
5. Failure caused by fire disaster, salt corrosion, gas corrosion, earthquake, windstorm, flood, lightning, abnormal voltage, or other force majeure.



Notice: the warranty scope only refers to inverter body.

Quality Assurance

Warranty Policy:

Warranty period: The warranty period of the solar water pump inverter is 24 months. The system components have a 12-month warranty.

Starting date of warranty period: the date when user gets goods from our dealer.

Warranty proof: product series number and local dealer's shipment invoice.

Notice: if client does not provide shipment invoice and other documents, the date 2 months after the delivery date will be used as the start date of the warranty period.

Scope: During the warranty period, the scope and liability of any damage should be evaluated by the distributor and manufacturer.

Warranty principle:

In order to provide better service for the end users of the company, the authorized dealers of the company will reply to the warranty request of the users. During warranty period, the dealer will replace all defective products and parts in aspects of design and production.

- (1) Warranty card is not sent to dealer or the manufacturer.
- (2) Product change, design alteration, or component replacement is not approved by the manufacturer.
- (3) Alter, change or try to repair it. The serial number is wiped out or does not have the manufacturer technician's seal.
- (4) Wrong installation and debugging
- (5) Does not abide by proper safety regulation (CQC standards, etc.)
- (6) The product is improperly stored and damaged by final user.
- (7) Transportation damage. During transportation, the paint is scratched. During unloading, if enough evidence is available, apply in insurance company as soon as possible.
- (8) Fail to abide by user's manual, installation guidance, and maintenance regulation.
- (9) Incorrect use or improper operation
- (10) Shortage of ventilating device
- (11) The product maintenance procedure does not abide by or implement an acceptable standard.
- (12) Force majeure (such as lightning, over-voltage, thunderstorm, fire disaster)

If claim exceeds the power quoted in warranty principle, the manufacturer shall not undertake

legal responsibilities, including the following conditions: claim compensation due to direct or indirect damaged caused by defective equipment; claim compensation due to the damage caused by removal and installation; profit loss not specified in the manufacturer's warranty scope.

Warranty and Claim Procedure:

Please send a simple failure description report to the manufacturer's local dealer. If we agree to replace, we will issue an equivalent replacement device according to model and year length. The rest warranty rights will be transferred to replacing equipment. Under such condition, as your power has been filed in the manufacturer, you will not receive a new certification. The substitute goods will be delivered within 2 working days. The defective equipment is to use the transportation packaging to transport to dealer. If on-site re-installation is necessary, the end-user shall consult with dealer in advance. All maintenance services during warranty period are free of charge.

Warranty Card

Client Name		Contact Person	
Client Address		Contact Tel.	
Product Specification		Procurement Date	
Equipment Code		Warranty Date (since production date)	
Distribution Unit (Seal)			

